

Write your name here

Surname

Other names

**Pearson Edexcel
International GCSE**

Centre Number

--	--	--	--	--

Candidate Number

--	--	--	--

Mathematics B

Paper 2



Tuesday 16 January 2018 – Morning
Time: 2 hours 30 minutes

Paper Reference

4MB0/02

You must have: Ruler graduated in centimetres and millimetres, protractor, compasses, pen, HB pencil, eraser, calculator. Tracing paper may be used.

Total Marks

Instructions

- Use **black** ink or ball-point pen.
- **Fill in the boxes** at the top of this page with your name, centre number and candidate number.
- Answer **all** questions.
- Answer the questions in the spaces provided – *there may be more space than you need.*
- **Calculators may be used.**

Information

- The total mark for this paper is 100.
- The marks for **each** question are shown in brackets – *use this as a guide as to how much time to spend on each question.*

Advice

- Read each question carefully before you start to answer it.
- Check your answers if you have time at the end.
- Without sufficient working, correct answers may be awarded no marks.

Turn over ►

P53306A

©2018 Pearson Education Ltd.

1/1/1/



Pearson

Answer ALL ELEVEN questions.

Write your answers in the spaces provided.

You must write down all the stages in your working.

- 1 The scale drawing opposite shows the positions, A , B and C , of three lighthouses. The points A , B and C lie at sea level in the same horizontal plane with B due north of A .

The scale of the drawing is 1 cm represents 50 km.

(a) Find by measurement

(i) the actual distance, in km, from A to B ,

(ii) the bearing of C from A .

(2)

A ship S is equidistant from A and C and 225 km from B .

(b) **Showing all your construction lines**, find and mark each of the two possible positions of S on the scale drawing with a cross (\times).

(2)

Given that S is east of the line AB ,

(c) find, by measurement, the bearing of S from A .

(1)

.....

.....

.....

.....

.....

.....

.....

.....

.....

.....

.....

.....

.....

.....

.....

.....

.....

.....

.....

.....

.....

.....

DO NOT WRITE IN THIS AREA

DO NOT WRITE IN THIS AREA

DO NOT WRITE IN THIS AREA



Question 1 continued

DO NOT WRITE IN THIS AREA

DO NOT WRITE IN THIS AREA

DO NOT WRITE IN THIS AREA

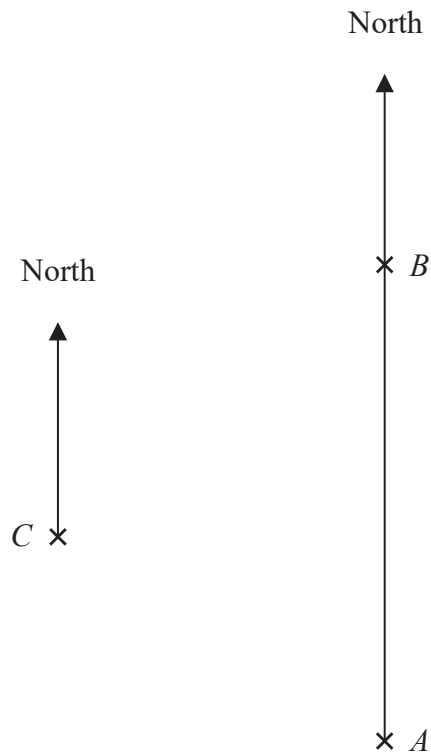

.....

.....

.....

.....

.....

.....

.....

.....

.....

.....

.....

.....

.....

.....

.....

.....

.....

.....

.....

.....

.....

.....

.....

(Total for Question 1 is 5 marks)



Question 2 continued

DO NOT WRITE IN THIS AREA

DO NOT WRITE IN THIS AREA

DO NOT WRITE IN THIS AREA

Handwriting practice area with 28 horizontal dotted lines.

(Total for Question 2 is 6 marks)



3

Diagram NOT accurately drawn

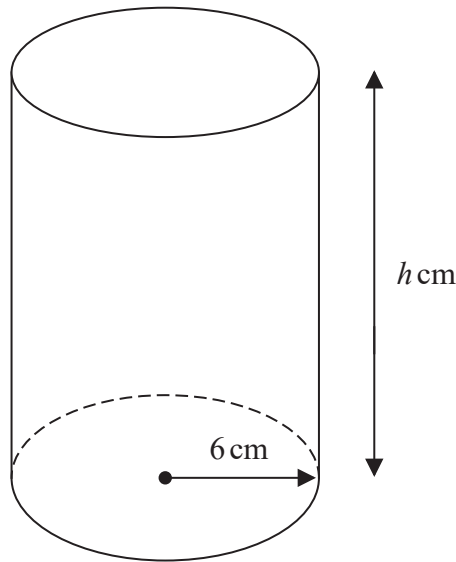

Figure 1

Figure 1 shows a solid right circular cylinder with a height of h cm and a radius of 6 cm.

Given that the total surface area of the cylinder is 252π cm²

(a) show that $h = 15$

(3)

A solid sphere has the same volume as the cylinder.

(b) Calculate the radius, in cm to 2 significant figures, of the sphere.

(4)

.....

.....

.....

.....

.....

.....

.....

.....

.....

$$\left[\begin{array}{l} \text{Area of circle} = \pi r^2 \\ \text{Curved surface area of right circular cylinder} = 2\pi r h \\ \text{Volume of sphere} = \frac{4}{3}\pi r^3 \end{array} \right]$$



Question 3 continued

DO NOT WRITE IN THIS AREA

DO NOT WRITE IN THIS AREA

DO NOT WRITE IN THIS AREA

Handwriting practice area with horizontal dotted lines.

(Total for Question 3 is 7 marks)



4 Sannia works in a shop. She is paid \$7.60 for each hour she works. She is also paid 4% of the value of the items she sells in a week.

In one week Sannia works for 36 hours and the value of the items she sells is \$4250

(a) Calculate Sannia’s total pay for that week. (2)

In another week Sannia works for 41 hours and her total pay for this week is \$430.80

(b) Calculate the value of the items Sannia sells this week. (2)

Sannia invested an amount of money for 3 years in a savings account. At the end of each year interest was added to her account.

At the end of the first year the interest added was 5.1% of the amount in the account.
At the end of the second year the interest added was 4.5% of the amount in the account.
At the end of the third year the interest added was 4.5% of the amount in the account.

At the end of the 3 years the amount in the account was \$2123.28

(c) Calculate the amount of money that Sannia invested.
Give your answer to the nearest \$.

(3)

.....

.....

.....

.....

.....

.....

.....

.....

.....

.....

.....

.....

.....

.....

.....

.....

.....

.....

.....

.....

.....

.....



Question 4 continued

DO NOT WRITE IN THIS AREA

DO NOT WRITE IN THIS AREA

DO NOT WRITE IN THIS AREA

Handwriting practice area with 28 horizontal dotted lines.

(Total for Question 4 is 7 marks)



5 A particle P is moving along a straight line.

At time t seconds, the displacement, s metres, of P from a fixed point (O) of the line is given by

$$s = t^3 - 9t^2 + 15t + 6 \quad t \geq 0$$

(a) Find the displacement of P from O when $t = 3$ (2)

At time t seconds, the velocity of P is v m/s.

(b) Find

(i) an expression for v in terms of t ,

(ii) the values of t for which P is instantaneously at rest. (4)

(c) Find the acceleration of P when $t = 4$ (3)



Question 5 continued

DO NOT WRITE IN THIS AREA

DO NOT WRITE IN THIS AREA

DO NOT WRITE IN THIS AREA

Handwriting practice area with 25 horizontal dotted lines.



Question 5 continued

Handwriting practice area consisting of 25 horizontal dotted lines.

DO NOT WRITE IN THIS AREA

DO NOT WRITE IN THIS AREA

DO NOT WRITE IN THIS AREA



Question 5 continued

DO NOT WRITE IN THIS AREA

DO NOT WRITE IN THIS AREA

DO NOT WRITE IN THIS AREA

Area with horizontal dotted lines for writing.

(Total for Question 5 is 9 marks)



6 The incomplete table and histogram give information about the weights of 100 tomatoes.

Weight (x grams)	Frequency
$20 < x \leq 30$	16
$30 < x \leq 35$	28
$35 < x \leq 40$	32
$40 < x \leq 50$	14
$50 < x \leq 70$	

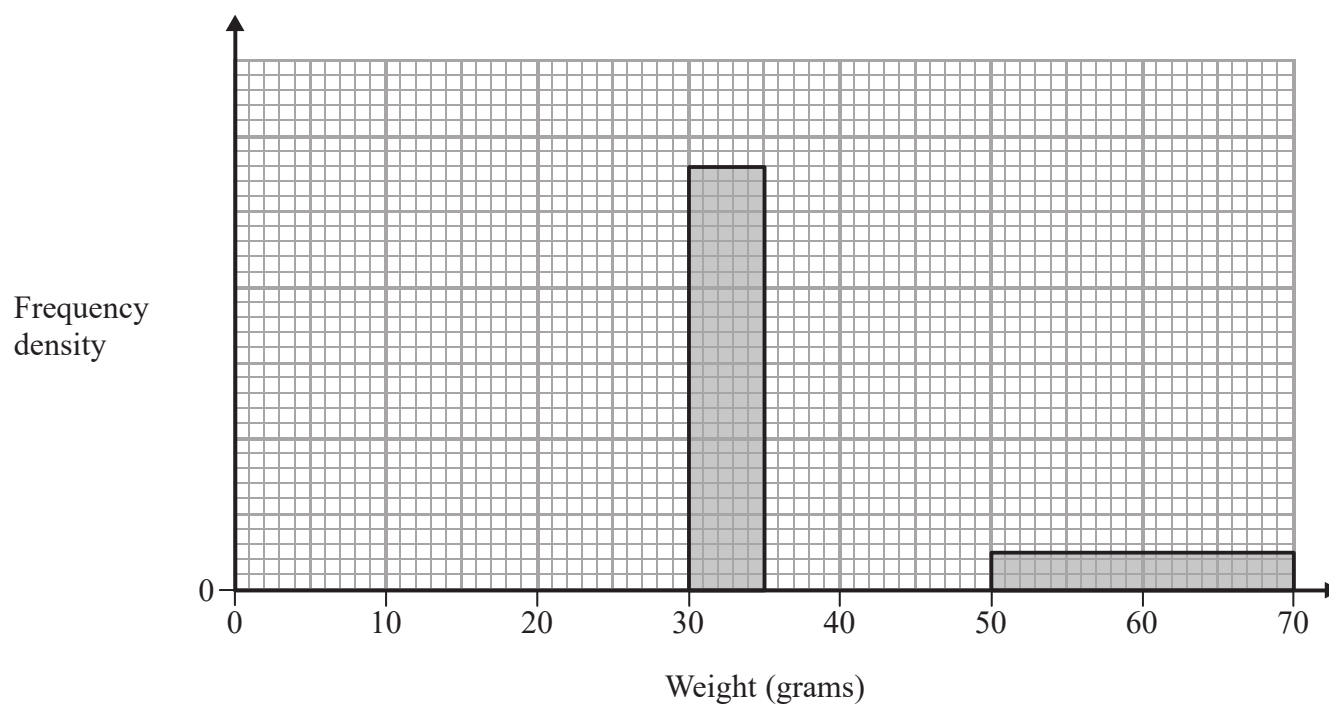

(a) Complete

(i) the table,

(1)

(ii) the histogram.

(3)

(b) Calculate an estimate for the mean weight of the 100 tomatoes.

(4)

.....

.....

.....

.....



Question 6 continued

DO NOT WRITE IN THIS AREA

DO NOT WRITE IN THIS AREA

DO NOT WRITE IN THIS AREA

A large grid of horizontal dotted lines for writing answers.

Turn over for a spare grid if you need to redraw your histogram.



Question 6 continued

Handwriting practice area consisting of 25 horizontal dotted lines.

DO NOT WRITE IN THIS AREA

DO NOT WRITE IN THIS AREA

DO NOT WRITE IN THIS AREA



Question 6 continued

Only use this grid if you need to redraw your histogram.

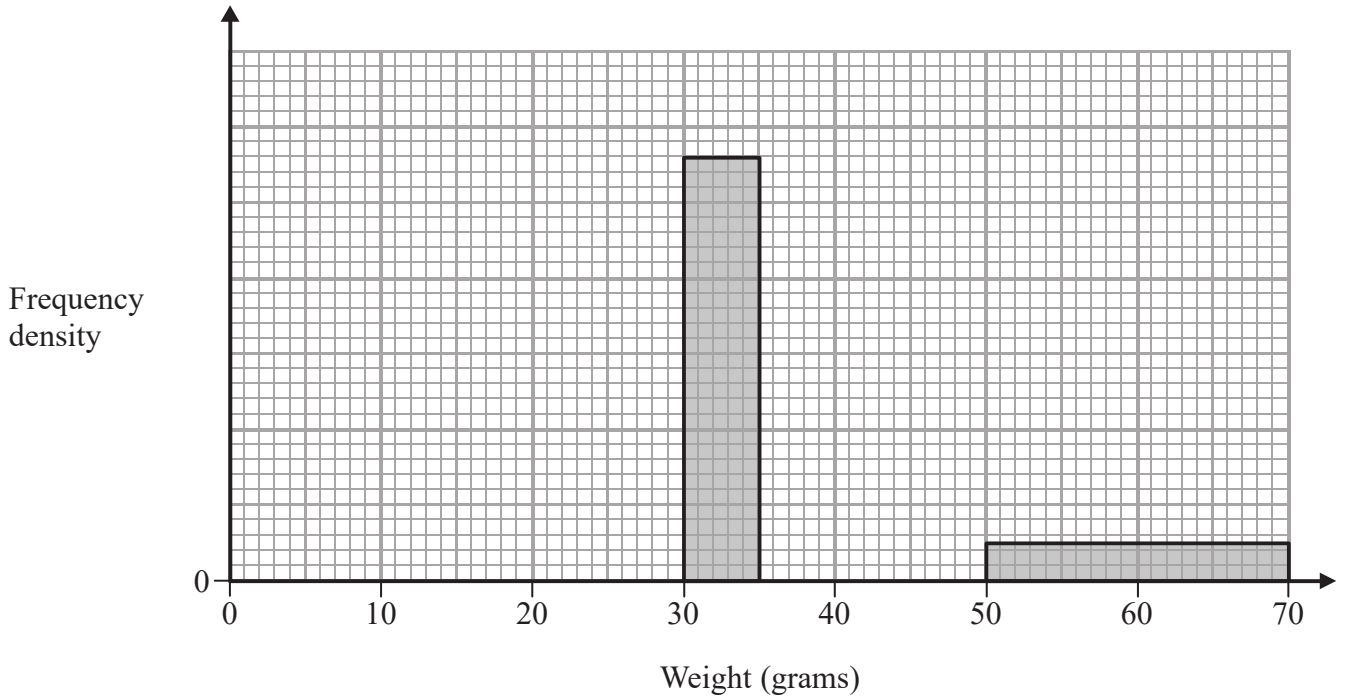

DO NOT WRITE IN THIS AREA

DO NOT WRITE IN THIS AREA

DO NOT WRITE IN THIS AREA

(Total for Question 6 is 8 marks)



7 Tariq either catches the bus to school or he walks to school.

On any day that he goes to school, the probability that he catches the bus is 0.4

On any day that he goes to school, the probability that he catches the bus **and** is late for school is 0.1

(a) Calculate the probability that Tariq is late for school when he catches the bus.

(2)

The probability that Tariq is late for school when he walks is 0.05

(b) Complete the probability tree diagram.

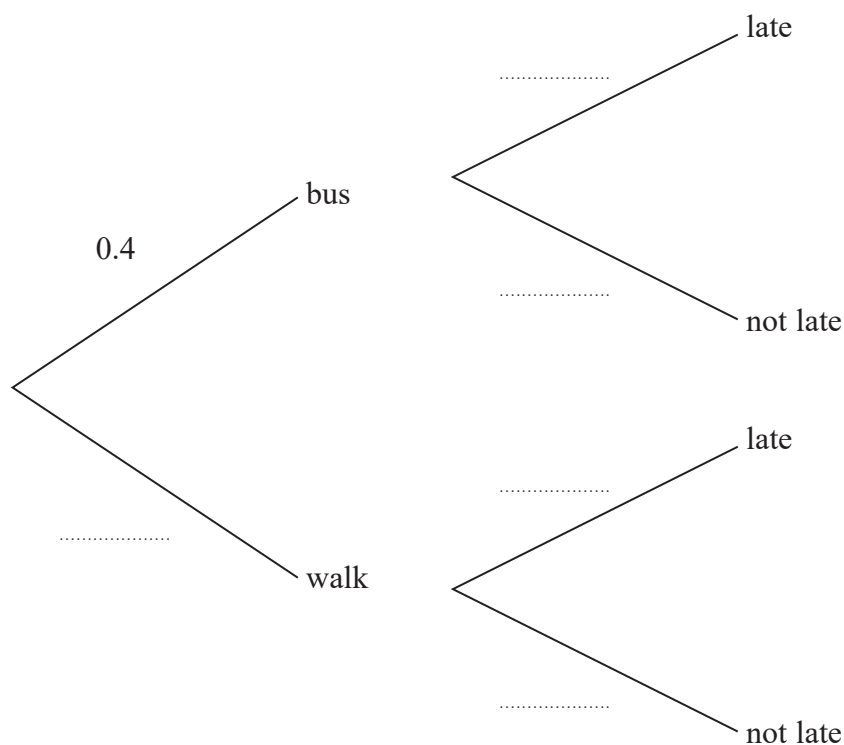

(3)

(c) Find the probability that, on any day he goes to school, he is not late for school.

(2)

.....

.....

.....

.....

.....

.....

.....

.....

.....

.....



Question 7 continued

DO NOT WRITE IN THIS AREA

DO NOT WRITE IN THIS AREA

DO NOT WRITE IN THIS AREA

Area with horizontal dotted lines for writing.

(Total for Question 7 is 7 marks)



8 The diagram shows two triangles A and B .

(a) Describe fully the single transformation that maps triangle A onto triangle B .

(3)

Triangle B is transformed to triangle C by the enlargement with scale factor $-\frac{1}{2}$ and centre of enlargement $(4, -2)$.

(b) On the grid, draw and label triangle C .

(3)

Triangle D is transformed to triangle A under the transformation with matrix \mathbf{T} where

$$\mathbf{T} = \begin{pmatrix} 0 & -2 \\ -2 & 1 \end{pmatrix}$$

(c) Find the coordinates of the vertices of triangle D .

(4)

.....

.....

.....

.....

.....

.....

.....

.....

.....

.....

.....

.....

.....

.....

.....

.....

.....

.....

.....

.....

.....

$$\left[\text{Inverse of matrix } \begin{pmatrix} a & b \\ c & d \end{pmatrix} = \frac{1}{ad - bc} \begin{pmatrix} d & -b \\ -c & a \end{pmatrix} \right]$$



DO NOT WRITE IN THIS AREA

DO NOT WRITE IN THIS AREA

DO NOT WRITE IN THIS AREA

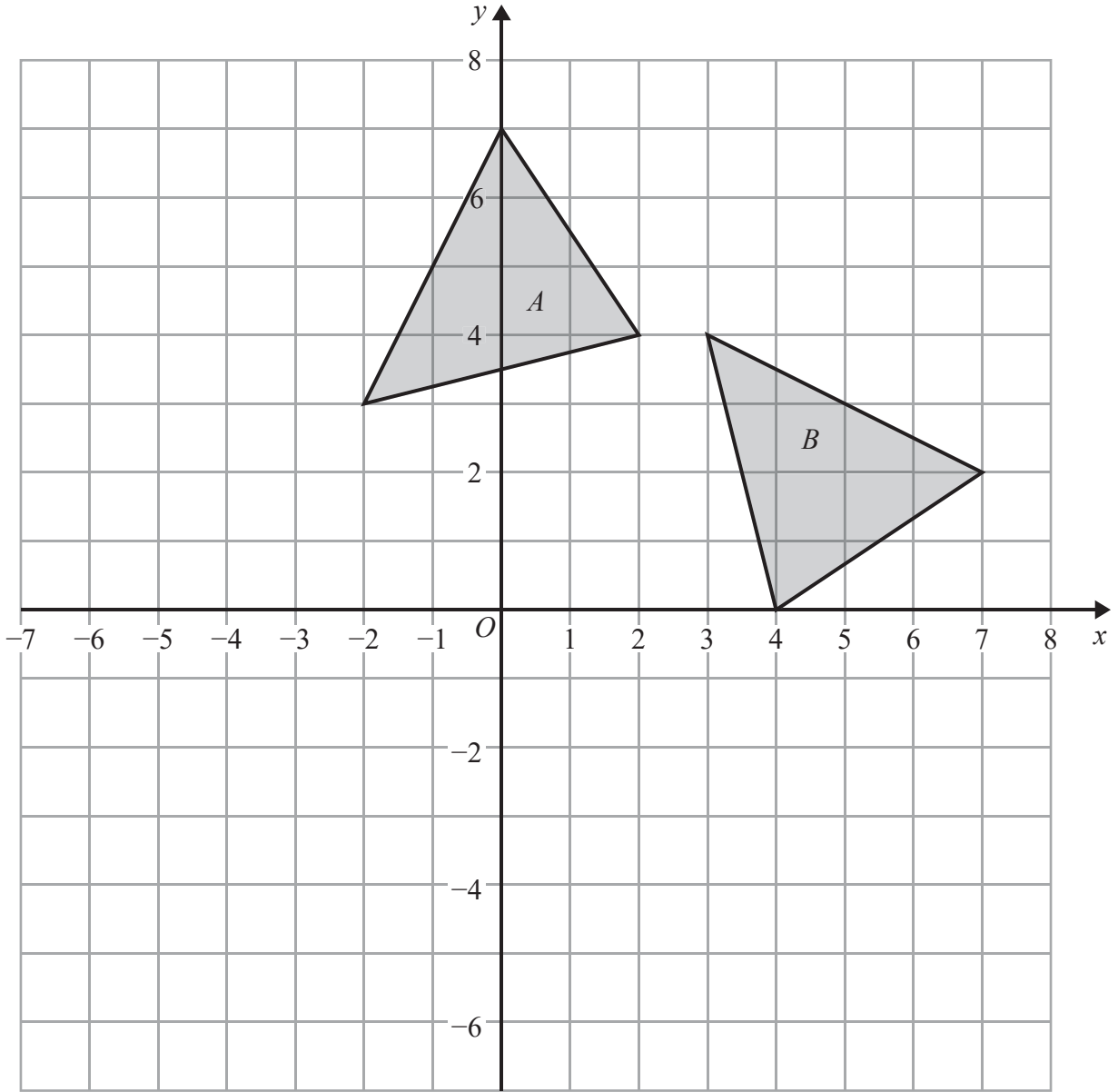

.....

.....

.....

.....

.....

.....

.....

.....

.....

.....

Turn over for a spare grid if you need to redraw your triangles.



Question 8 continued

Area with horizontal dotted lines for writing.

DO NOT WRITE IN THIS AREA

DO NOT WRITE IN THIS AREA

DO NOT WRITE IN THIS AREA



Question 8 continued

Only use this grid if you need to redraw your triangles.

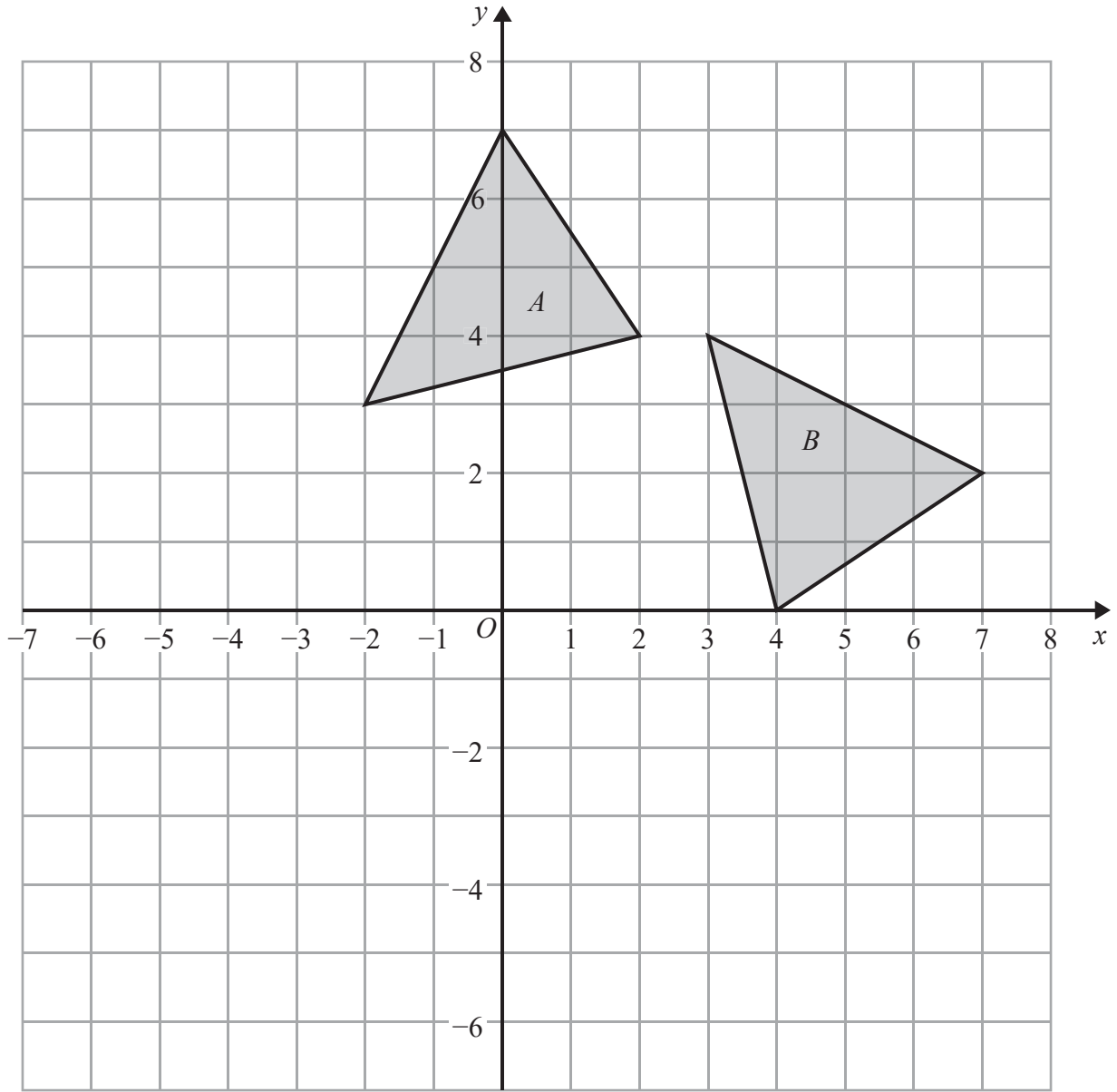

DO NOT WRITE IN THIS AREA

DO NOT WRITE IN THIS AREA

DO NOT WRITE IN THIS AREA

.....

.....

.....

.....

.....

.....

.....

(Total for Question 8 is 10 marks)



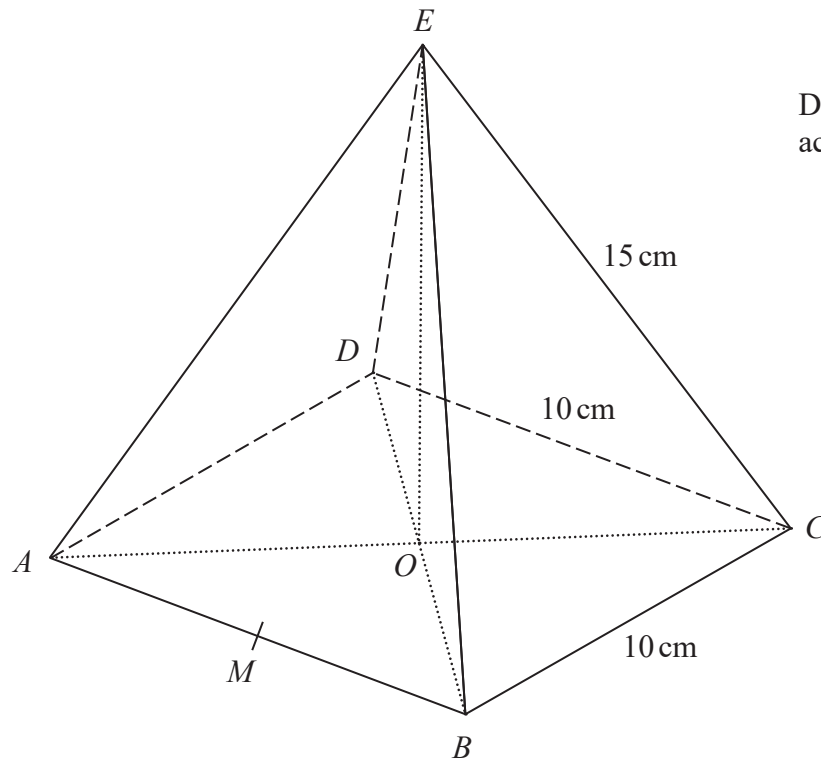

Diagram NOT
accurately drawn

Figure 2

A solid right pyramid has a square base $ABCD$ and vertex E as shown in Figure 2.

$$AB = BC = CD = AD = 10 \text{ cm} \quad \text{and} \quad EA = EB = EC = ED = 15 \text{ cm}$$

The diagonals of the base of the pyramid cross at the point O .

- (a) Show that the height EO of the pyramid is $5\sqrt{7}$ cm. (3)

The midpoint of AB is M , as shown in Figure 2.

- (b) Find the size, in degrees to 1 decimal place, of $\angle EMO$. (2)

- (c) Find the size, in degrees to 1 decimal place, of $\angle AEB$. (3)

- (d) Hence calculate, in cm^2 to 3 significant figures, the **total** surface area of the pyramid. (4)

$$\left[\begin{array}{l} \text{Cosine rule: } a^2 = b^2 + c^2 - 2bc \cos A \\ \text{Area of triangle} = \frac{1}{2} ab \sin C \end{array} \right]$$



Question 9 continued

DO NOT WRITE IN THIS AREA

DO NOT WRITE IN THIS AREA

DO NOT WRITE IN THIS AREA

Area with horizontal dotted lines for writing.



Question 9 continued

Handwriting practice area consisting of 25 horizontal dotted lines.

DO NOT WRITE IN THIS AREA

DO NOT WRITE IN THIS AREA

DO NOT WRITE IN THIS AREA



Question 9 continued

DO NOT WRITE IN THIS AREA

DO NOT WRITE IN THIS AREA

DO NOT WRITE IN THIS AREA

Area with horizontal dotted lines for writing.

(Total for Question 9 is 12 marks)



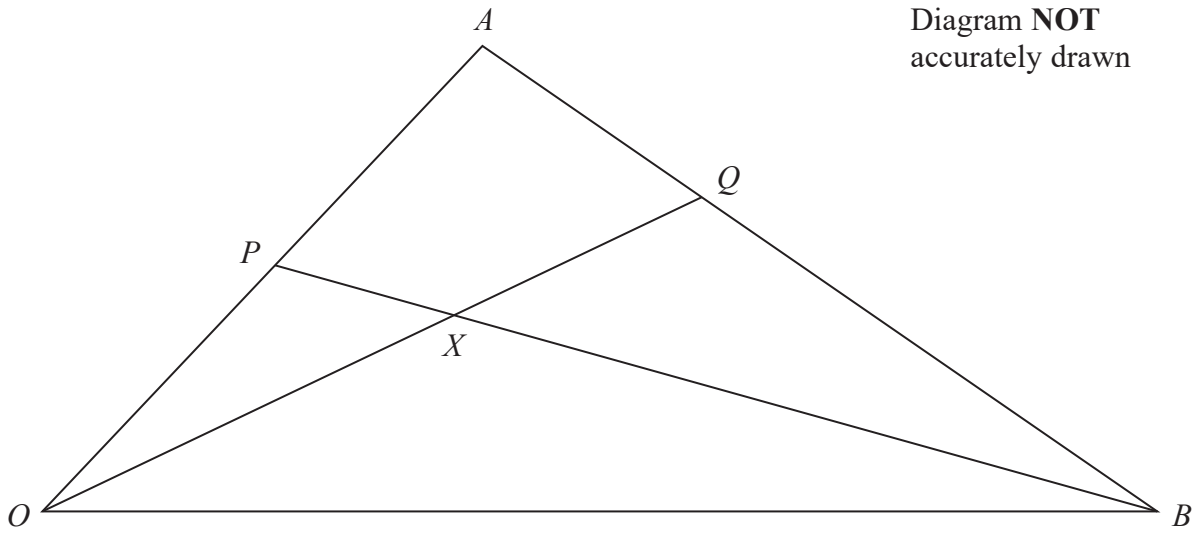

Figure 3

In Figure 3, $\vec{OA} = 4\mathbf{a}$ and $\vec{OB} = 3\mathbf{b}$

P is the point on OA such that $OP:OA = 1:2$

Q is the point on AB such that $AQ:AB = 2:5$

(a) Find as simplified expressions in terms of \mathbf{a} and \mathbf{b}

- (i) \vec{PB}
- (ii) \vec{OQ}

(3)

The lines OQ and BP intersect at the point X .

Given that $\vec{OX} = \lambda\vec{OQ}$ and $\vec{PX} = \mu\vec{PB}$, where λ and μ are scalars,

(b) write down an expression for \vec{AX}

- (i) in terms of \mathbf{a} , \mathbf{b} and λ ,
- (ii) in terms of \mathbf{a} , \mathbf{b} and μ .

(4)

(c) Hence find the value of λ and the value of μ .

(3)

The area of triangle AXQ is 10 square units.

(d) Find the area of triangle OPX .

(3)

.....

.....

.....

.....

.....

DO NOT WRITE IN THIS AREA

DO NOT WRITE IN THIS AREA

DO NOT WRITE IN THIS AREA



Question 10 continued

DO NOT WRITE IN THIS AREA

DO NOT WRITE IN THIS AREA

DO NOT WRITE IN THIS AREA

Handwriting practice area with 25 horizontal dotted lines.



Question 10 continued

Handwriting practice area consisting of 20 horizontal dotted lines.

DO NOT WRITE IN THIS AREA

DO NOT WRITE IN THIS AREA

DO NOT WRITE IN THIS AREA



Question 10 continued

DO NOT WRITE IN THIS AREA

DO NOT WRITE IN THIS AREA

DO NOT WRITE IN THIS AREA

Area with horizontal dotted lines for writing.

(Total for Question 10 is 13 marks)



11

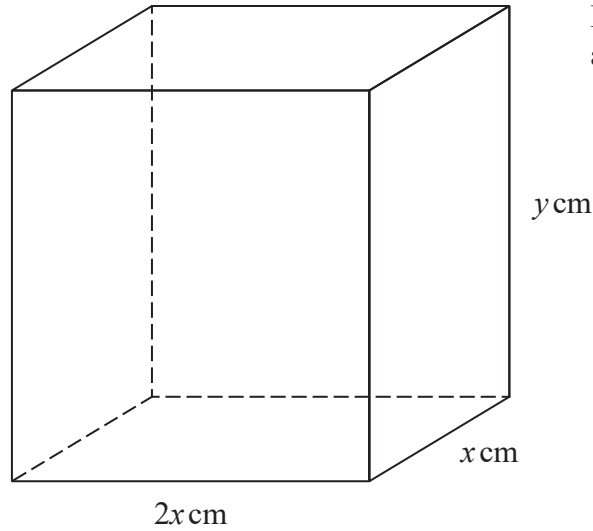

Diagram NOT accurately drawn

Figure 4

Figure 4 shows a solid cuboid with dimensions x cm, $2x$ cm and y cm.

Given that the volume of the cuboid is 24 cm^3

- (a) find a formula for y in terms of x . (2)

The total surface area of the cuboid is $S \text{ cm}^2$

- (b) Show that $S = 4x^2 + \frac{72}{x}$ (2)

- (c) Using calculus, find the value of x , to 3 significant figures, for which S is a minimum. (4)

- (d) Hence find, to 3 significant figures, the minimum value of S . (1)

.....

.....

.....

.....

.....

.....

.....

.....

.....

.....

DO NOT WRITE IN THIS AREA

DO NOT WRITE IN THIS AREA

DO NOT WRITE IN THIS AREA



Question 11 continued

DO NOT WRITE IN THIS AREA

DO NOT WRITE IN THIS AREA

DO NOT WRITE IN THIS AREA

Area with horizontal dotted lines for writing.

Question 11 continues on the next page.



Question 11 continued

(e) Complete the following table of values for $S = 4x^2 + \frac{72}{x}$

Give your values of S to the nearest whole number where necessary.

x	1	1.5	2	2.5	3	3.5	4	4.5
$4x^2$	4	9	16	25			64	81
$\frac{72}{x}$	72	48	36	28.8			18	16
S	76	57	52	54			82	97

(2)

(f) On the grid opposite, plot the points from your completed table and, using your answers to parts (c) and (d), join them to form a smooth curve.

(3)

(g) Find an estimate to 1 decimal place of the range of values of x for which $S < 65$

(2)

.....

.....

.....

.....

.....

.....

.....

.....

.....

.....

.....

.....

.....

.....

.....

.....

.....

.....

.....

.....

.....

.....

.....

.....



Question 11 continued

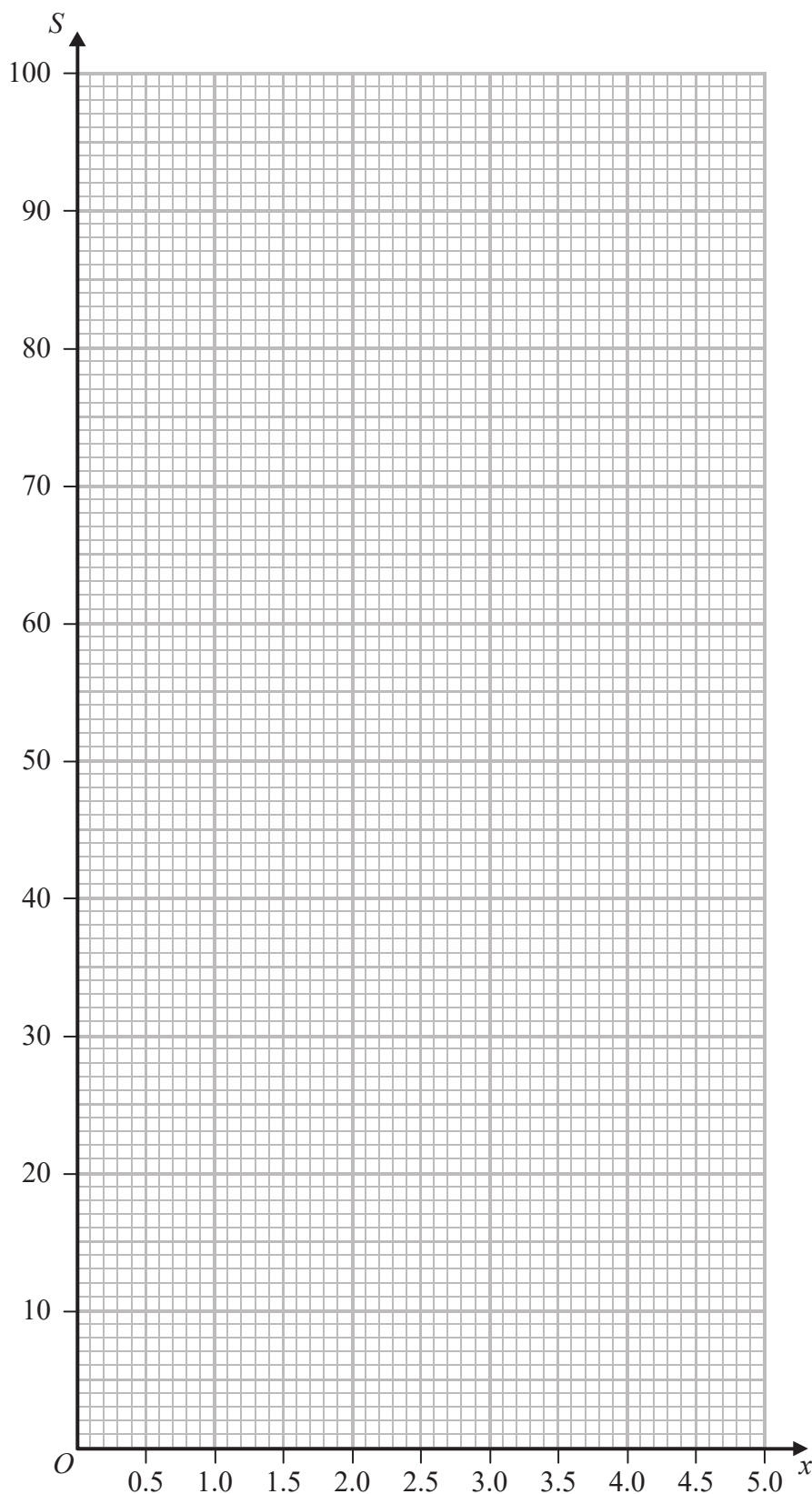

DO NOT WRITE IN THIS AREA

DO NOT WRITE IN THIS AREA

DO NOT WRITE IN THIS AREA

Turn over for a spare grid if you need to redraw your curve.



Question 11 continued

Only use this grid if you need to redraw your curve.

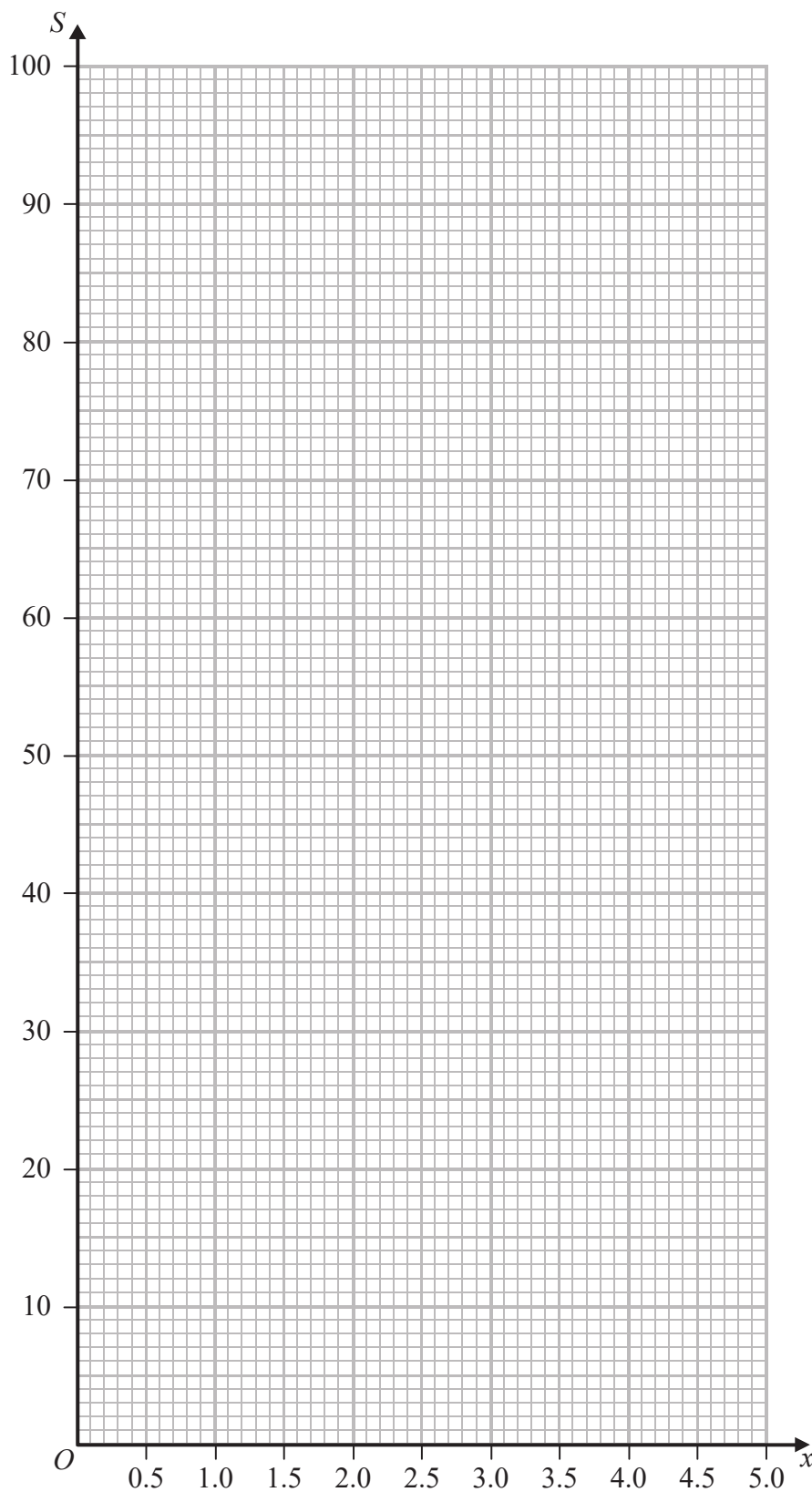

(Total for Question 11 is 16 marks)

TOTAL FOR PAPER IS 100 MARKS

DO NOT WRITE IN THIS AREA

DO NOT WRITE IN THIS AREA

DO NOT WRITE IN THIS AREA

